

Technical data sheet

Product features



Universal mixer planetary 10 speed 5 l 230 V

Model	SAP Code	00008696
--------------	-----------------	----------



- Device capacity [l]: 5.00
- Control type: Mechanical
- Safety cover: polycarbonate with squeegee
- Start /stop: Yes
- Safety element: total stop complete stop of the device in case of opening the container protects the operator from injury
- Number of speeds of device: 10
- Standard equipment for device: whisk, hook, stirrer
- Mixing system: With a fixed container
- Way of tool mounting: Planets

SAP Code	00008696	Net Weight [kg]	15.00
Net Width [mm]	330	Power electric [kW]	0.800
Net Depth [mm]	384	Loading	230 V / 1N - 50 Hz
Net Height [mm]	452	Device capacity [l]	5.00

Technical data sheet

Technical drawing



Universal mixer planetary 10 speed 5 l 230 V

Model

SAP Code

00008696

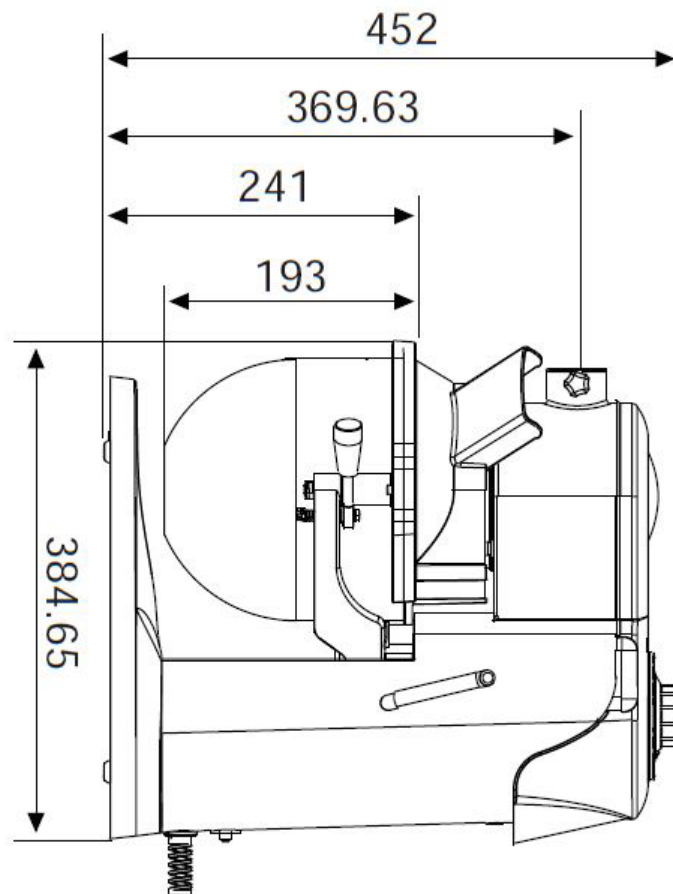
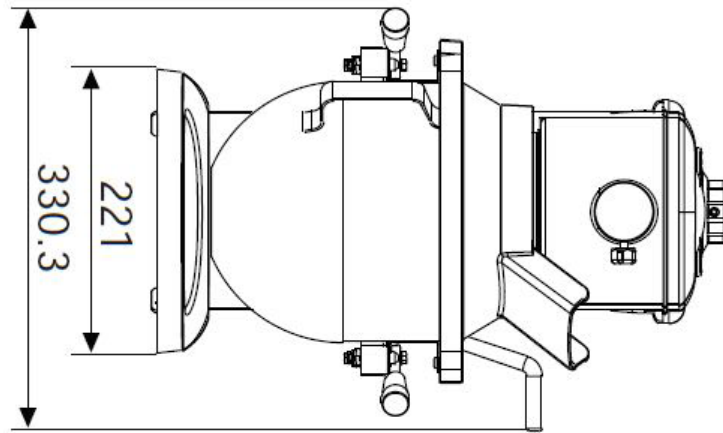

Technical data sheet

Product benefits



Universal mixer planetary 10 speed 5 l 230 V

Model

SAP Code

00008696

1

Planetary storage of attachments with 3 speeds

the attachments rotate around their axis and at the same time go around in a circle without the need to rotate the vessel (boiler)

- better mixing of ingredients; better quality of prepared dough

2

Additional devices

the possibility of grinding or grinding, or wiper arms, or handling carts

- multifunctionality

3

Content 5 80L

wide sortiment

- always the ideal size for every operation

4

Safety microswitch

without closing the microswitch, the machine will not start

- avoiding possible injury to the operator

5

Protective cover with filling opening

without closing the microswitch, the machine will not start

- Ingredients can be added additionally while ensuring the safety of the staff

6

Whisk, hook, stirrer

great basic equipment

- there is no need to buy additional equipment for whipping or kneading

7

No oil bath

the robot has a gearbox that is not stored in an oil basin

- no release of gear oil into the food

8

Reduction boiler

possibility to buy a reducing boiler that fits comfortably in a larger machine, but the volume is smaller than the boiler original

- simplification of working with smaller volumes of raw materials; the customer does not have to buy a second smaller machine afterwards

Technical data sheet

Technical parameters



Universal mixer planetary 10 speed 5 l 230 V

Model

SAP Code

00008696

1. SAP Code:

00008696

2. Net Width [mm]:

330

3. Net Depth [mm]:

384

4. Net Height [mm]:

452

5. Net Weight [kg]:

15.00

6. Gross Width [mm]:

360

7. Gross depth [mm]:

415

8. Gross Height [mm]:

500

9. Gross Weight [kg]:

17.00

10. Device type:

Electric unit

11. Power electric [kW]:

0.800

12. Loading:

230 V / 1N - 50 Hz

13. Device capacity [l]:

5.00

14. Number of speeds of device:

10

15. Control type:

Mechanical

16. Safety cover:

polycarbonate with squeegee

17. Safety element:

total stop complete stop of the device in case of opening the container protects the operator from injury

18. Way of tool mounting:

Planets

19. Safety Microswitch:

Yes

20. Start /stop:

Yes

21. Timer:

No

22. Standard equipment for device:

whisk, hook, stirrer

23. Unmountable bowl:

Yes

24. Suitable operations:

Mixing, whipping and kneading

25. Mixing system:

With a fixed container

26. Image for addition:

65F412BC-4D18-4EBD-958B-8DFF8BA98E9B